

Stk / pcs	Bezeichnung / Description	Typ-Nr. / Type-No.	Bemerkung / Remarks
①	Kabelwinkelstecker Cable mount angle plug	siehe Tabelle rechts! see chart on the right side!	
②	Kabelstecker Cable mount plug	526.42.1410.021 (1071645)	Laenge / Length
③	Kabel Cable	siehe Tabelle rechts! see chart on the right side!	
④			
⑤			
⑥			
⑦			
⑧			

Stk. pcs	Kabel Nr. Cable No.	Kunden Art.-Nr. Customer part No.	Kabeltyp Cable typ	Art.-Nr. IMS Part No. IMS	Zuschnittsl. l Cut length l	Gesamtlänge L Total length L
③	1	K-2602-01	Enviroflex 316	(1128687)	196,9 ± 1	200 ± 2
	1	K-2602-02	Enviroflex 316	(1128687)	196,9 ± 1	200 ± 2

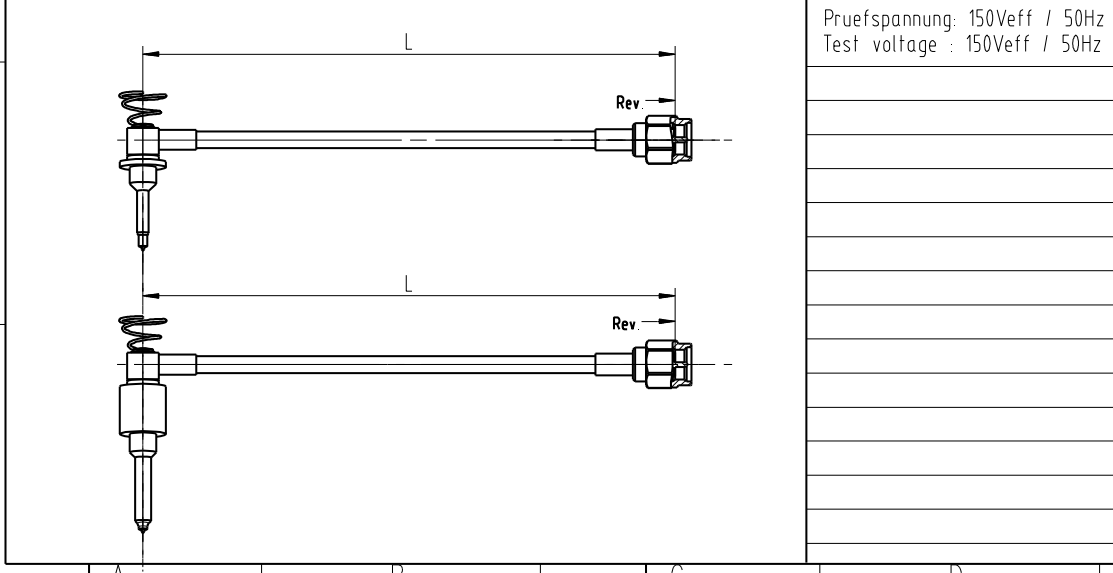
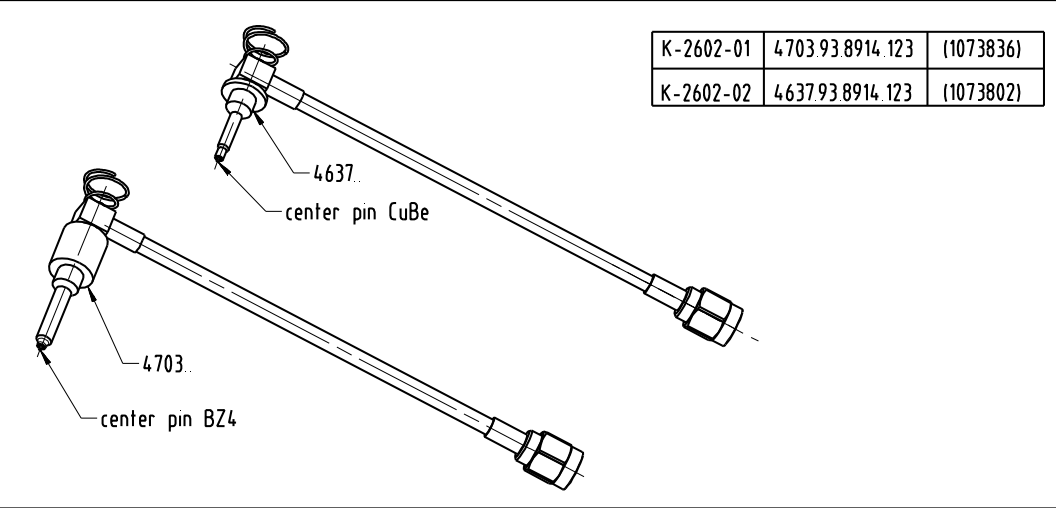
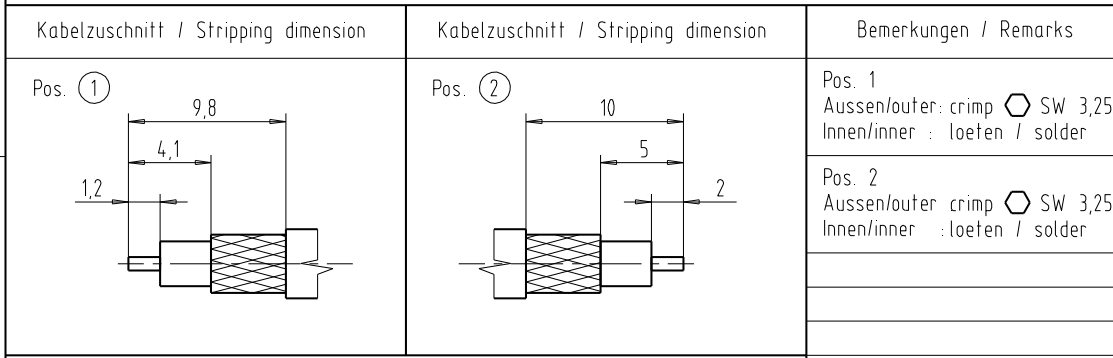

		general tolerance	ISO 2768	AA-CS-12	scale:
			MIT		
		date	06.02.09	name	Muellingner
		checked			
		Norm	053584		
EC_055_14	d	Material center pin add.	14.07.14	CMB	HF-Leitung Flexibel RF-flexible Cable Assembly K-2602-XX
design	C	zwei Stecker definiert	20.04.10	CMB	
design	b	Stecker 4703.in 4637.gea.	22.12.09	CMB	
design	a	Kabelwinkelst. gea.	12.10.09	CMB	
nr.	rev.	alteration	date	name	
					Rev. d