

Bereich für Dichtring!  
Area for sealing!

Steckbereich nach IEC 61169-54  
Mating area acc. IEC 61169-54

M/s 1:1

Einzelheit / detail A  
M/s 10:1

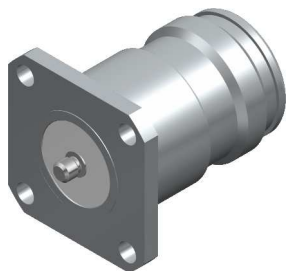
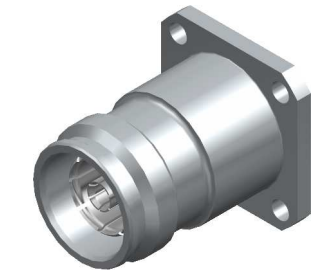
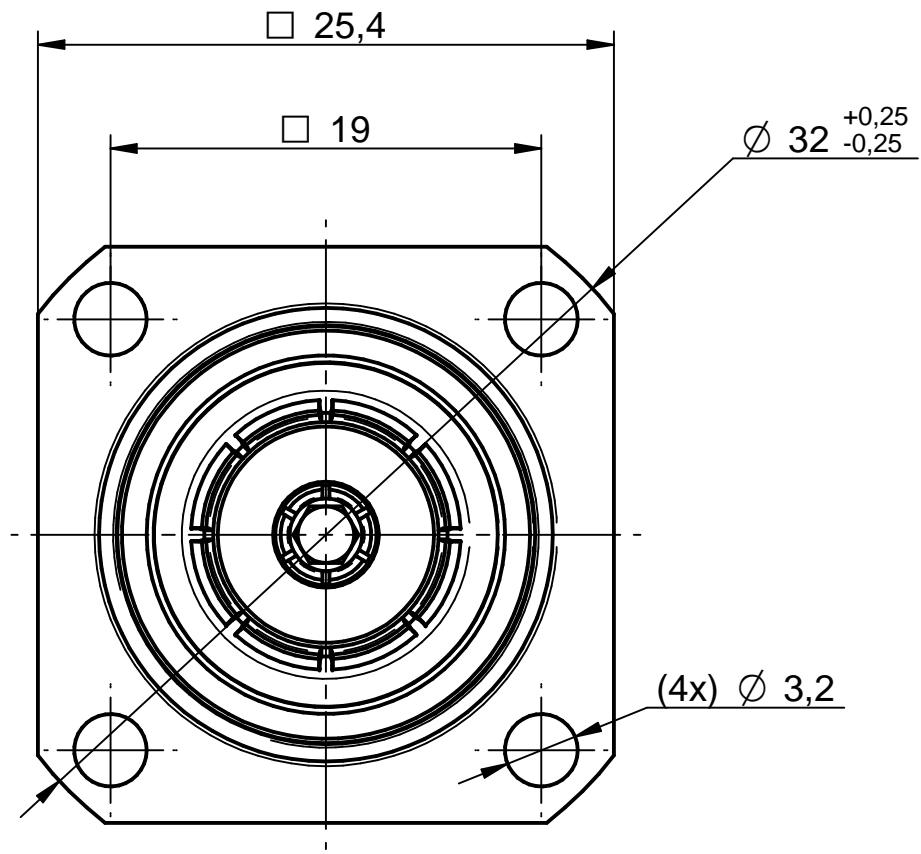

Mechanische Eigenschaften / mechanical requirement		
Steckzyklen Connecting operation	Op min.	100
Haltekraft Innenleiter in Richtung <b>1</b> Retention force of centre pin in direction <b>1</b>	min.	30N
Haltekraft Innenleiter in Richtung <b>2</b> Retention force of centre pin in direction <b>2</b>	min.	30N
Haltemoment Innenleiter Detent torque of centre pin	min.	3Ncm

IMS CONNECTOR SYSTEMS		general tolerance ISO 2768 mH angle: ±5°	scale: 3:1		
		date name	Assembly instruction: Stripping dimension:		
generate	30.06.16	Csenki	4.3/10-Flanschbuchse		
checked			4.3/10-Flange mount jack		
Norm			5351.VDZ.2018.20'		
nr.	rev.	alteration	date	name	Rev.