

Deckel eingepresst
mit Werkzeug AGK-1835
Cap pressed in with
tool no. AGK-1835

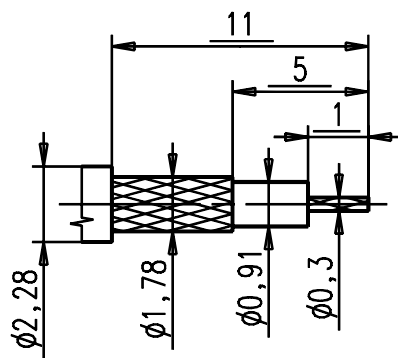

Kabelzuschnitt
Stripping dimension

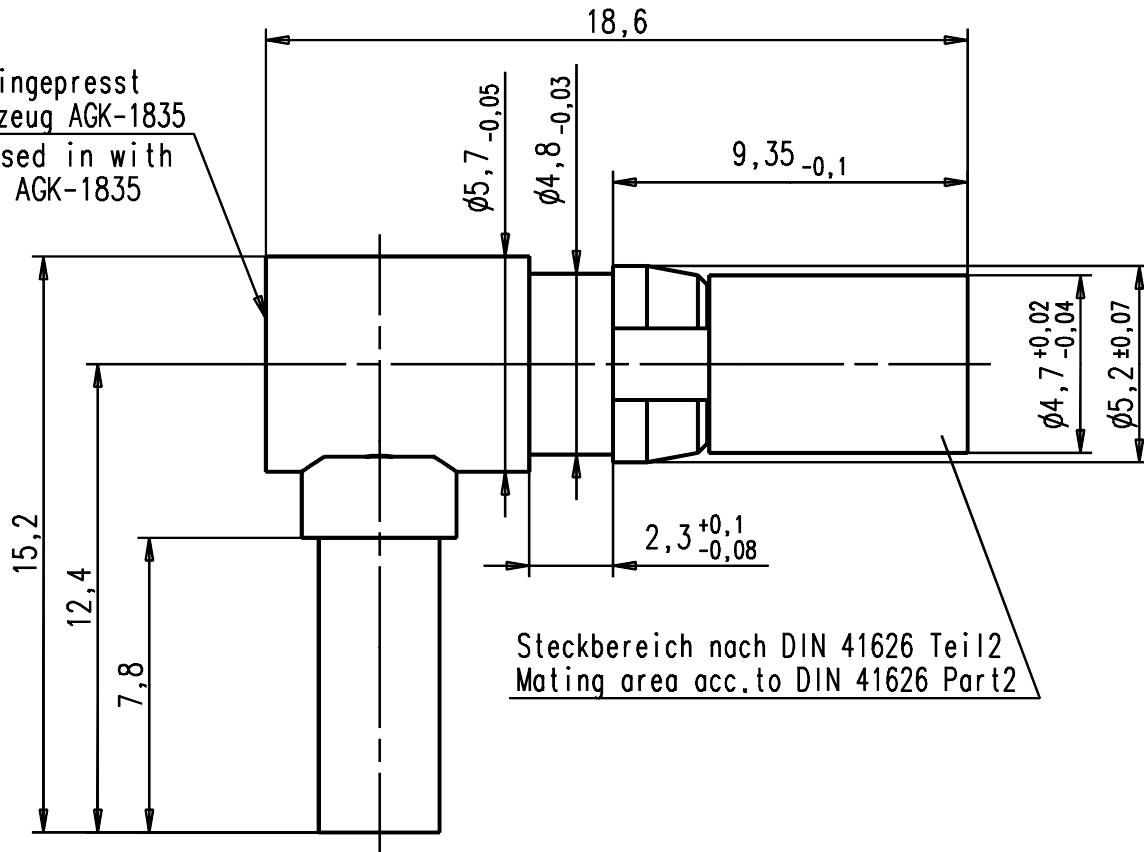
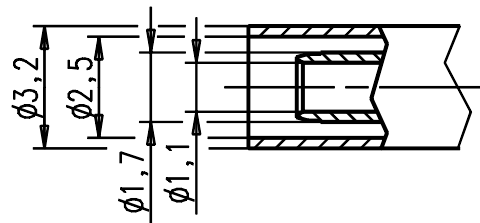

Nur fuer Kabeltyp : RG178 doppelt geschirmt
Only for cable typ: RG178 double braid screen

		general tolerance ISO 2768 mH		scale: 5:1	
				Assembly instruction: M38 Stripping dimension: K2	
			generate	date	name
			checked		
			Norm		
			36723		
					3332.53.1425.41'
nr.	rev.	alteration	date	name	