

Steckbereich nach:
Mating area acc. to:
EN 122340

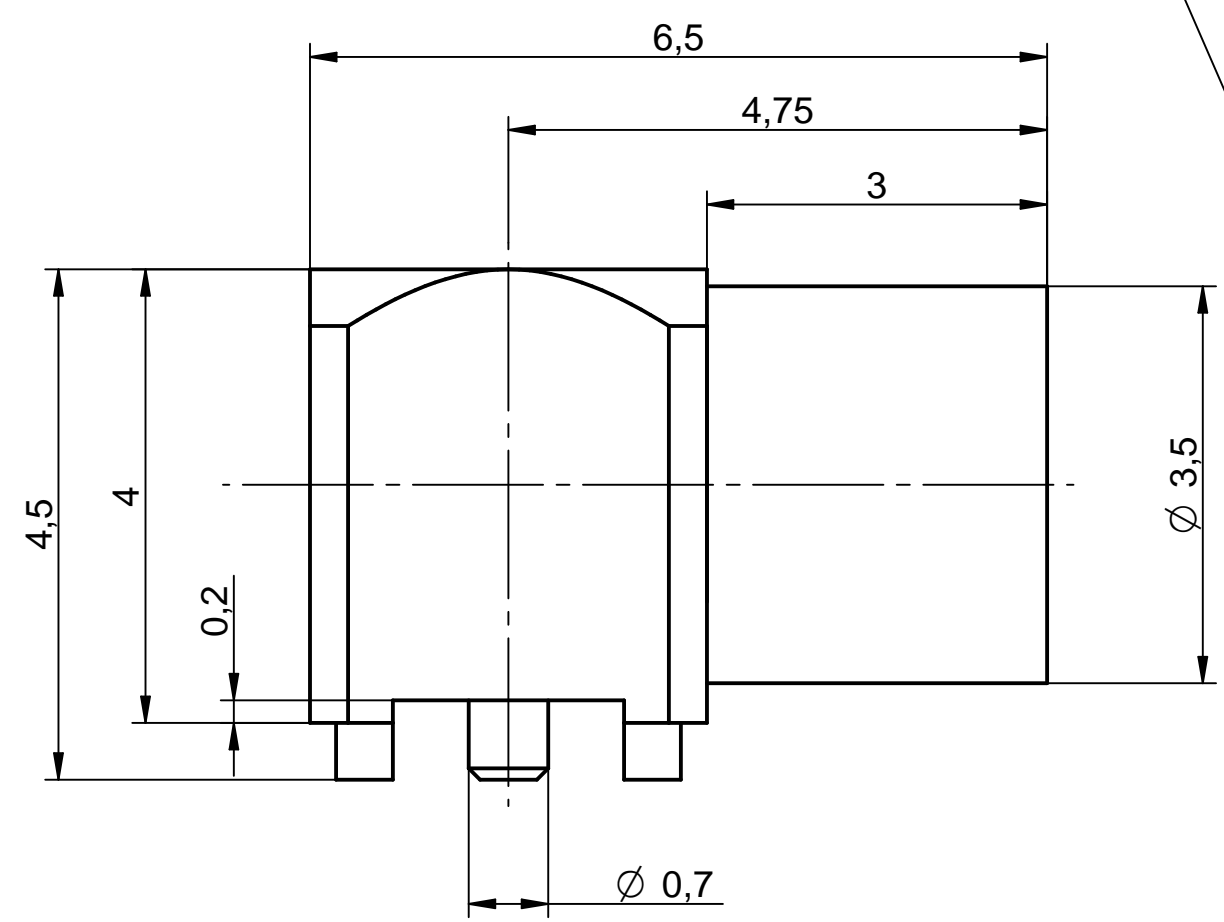

Blistergurt	AGK-4610	Tape and reel
Stck/Gurt	ca. 1800	Parts/reel
Stck/m	125	Parts/m
Vorlauf	240mm = 30 Kavitäten	Forward run
Nachlauf	240mm = 30 Kavitäten	After run
Gurtlänge	14880mm = 1860 Kavitäten	Reel length
Spullendurchmesser	330mm	Reel diameter

M/s 5:1

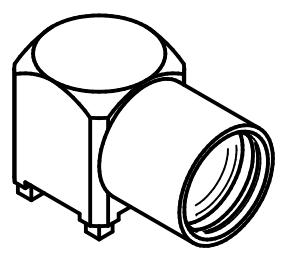

M/s 1:1



		general toleranc ISO 2768 mH angle: ± 5°	scale: 15:1			
			Assembly instruction: Stripping dimension:			
design	b	tape and reel chart	09.01.17	F Fab.	MMCX(f)-Anbauwinkelbuchse MMCX(f)- P.c.b. mount angle jack 5064.09.2520.00 ¹	Rev. b
design	a	tape and reel add.	28.08.16	F Fab.		
nr.	rev.	alteration	date	name		

