

Einzelheit / detail X  
M/s 20:1

Messpunkt für Schichtstärke  
Measuring point for plating

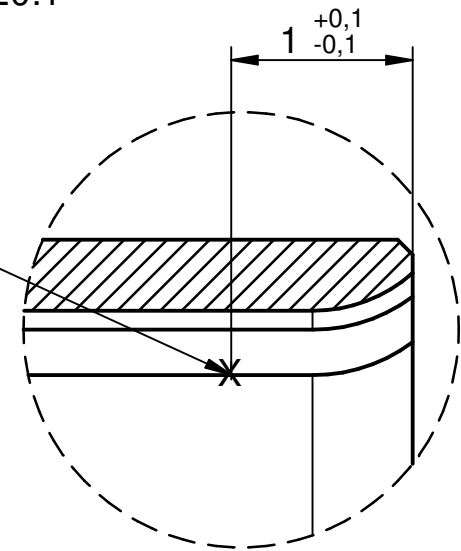

Federlappen Zusammengespreßt  
um Kraftanforderungen zu erfüllen . /  
Spring tabs pressed together  
to meet force requirements.

					general tolerance ISO 2768 mH angle: ± 5°	scale: 10:1		
						Max. Kontaktstrom: 40 A Max. contact current: 40 A		
					date	name	<b>Hochstrombuchse</b> Mount power insert female	
					generate	14.08.09		Pölz
					checked	12.07.07		F. Fab
					Norm			
							4694.24.2015.40'	Rev.
EC_103_17	b	revised	12.07.17	Pölz				b
EC_027_12	a	revised	07.03.12	lhen				
nr.	rev.	alteration	date	name			surface code	