

Kabelzuschnitt / Stripping dimension:  
Kabel / cable: Hirose U.FL-LP-066

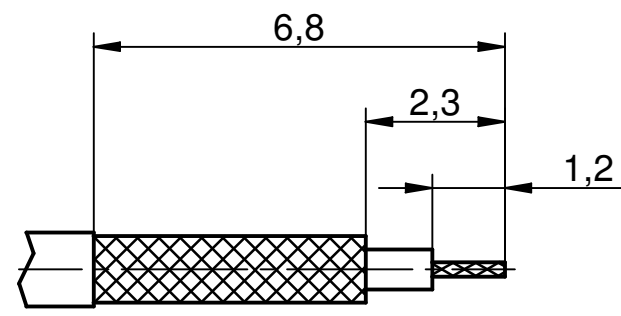

(Nicht IEC-Standard!!)  
(No IEC-Standard!!)

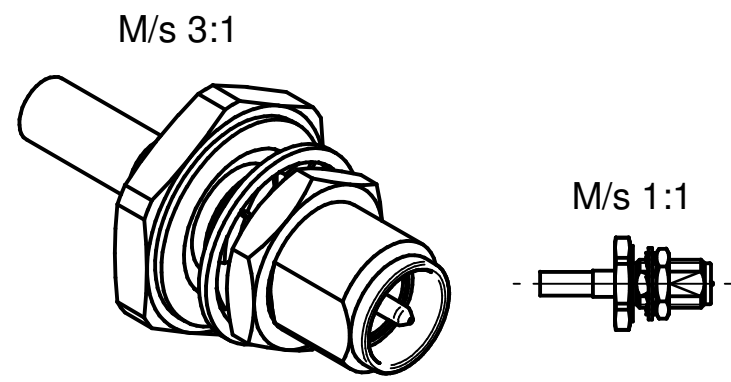

<b>IMS CONNECTOR SYSTEMS</b>				general tolerance ISO 2768 mH angle: ± 5°		scale: 8:1	
				date		name	
generate		02.10.07		Pölz		Assembly instruction: M-221 Stripping dimension:	
checked						SMA-Kabelstecker rev. pol.	
Norm						SMA-cable mount plug rev. pol.	
EC_080_11		a		Crimp tool		4401.42.1410.04'	
nr.		rev.		alteration		date	
		15.07.11		Varga		Rev. a	
		date		name			