

- 1) Steckkraft mit Buchse
Mating force with jack
max. 15N
- 2) Abzugskraft mit Buchse
Unmating force with jack
ca. 10N

Kabelzuschnitt / Stripping dimension

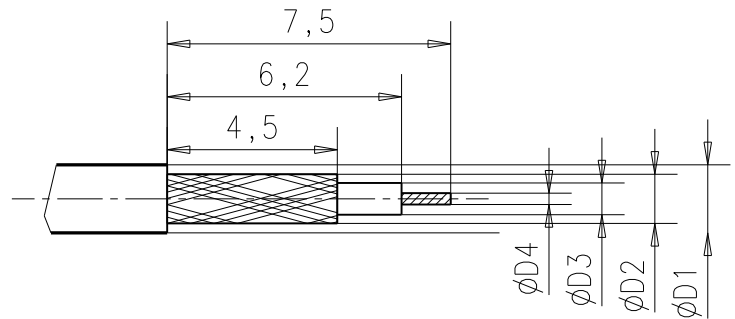

M/scale2:1

M/scale1:1

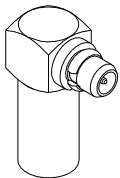

Fuer Kabel /
For cable

Gr.	TYPE TYP	$\phi D1$ MAX.	$\phi D2$ MAX.	$\phi D3$ MAX.	$\phi D4$ MAX.	$\phi D5$	$\phi D6$	$\phi D7$	$\phi D8$	Crimp Aussen/out
1	RG 178 BU;RG 196 AU;	2.10	1.30	0.90	0.30	0.90	1.70	2.50	4.00	2,67
2	RG 174 AU;RG 316 U;	2.80	2.20	1.55	0.54	1.60	2.30	3.00	4.00	3.25
3										
4										
5	RG 316 U-d;	3.10	2.50	1.55	0.54	1.60	2.30	3.30	4.00	3.25

IMS CONNECTOR
SYSTEMS

general tolerance
ISO 2768
mH

scale: 5:1

Assembly instruction:
Stripping dimension:

date name
20.05.98 Schwaer
checked
Norm
30284

Winkelstecker
Angle plug

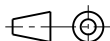

2401.09.1420.0''

Rev.
b

nr.	rev.	alteration	date	name
689/02	b	Revised cable-tab.	08.10.02	RSc
685/01	a	Revised cableg. 2	13.11.01	RSc