

**Customer Assembly Instruction**

<b>Number:</b>	<b>M-260</b>	<b>Nummer:</b>
<b>Description:</b>	<b>4.3-10-Flange mount cable jack</b>	<b>Beschreibung:</b>
		

**Recommended Soldering Process**

Inductive soldering

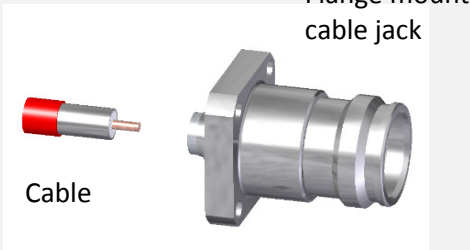
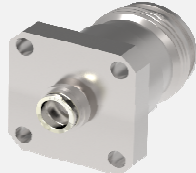
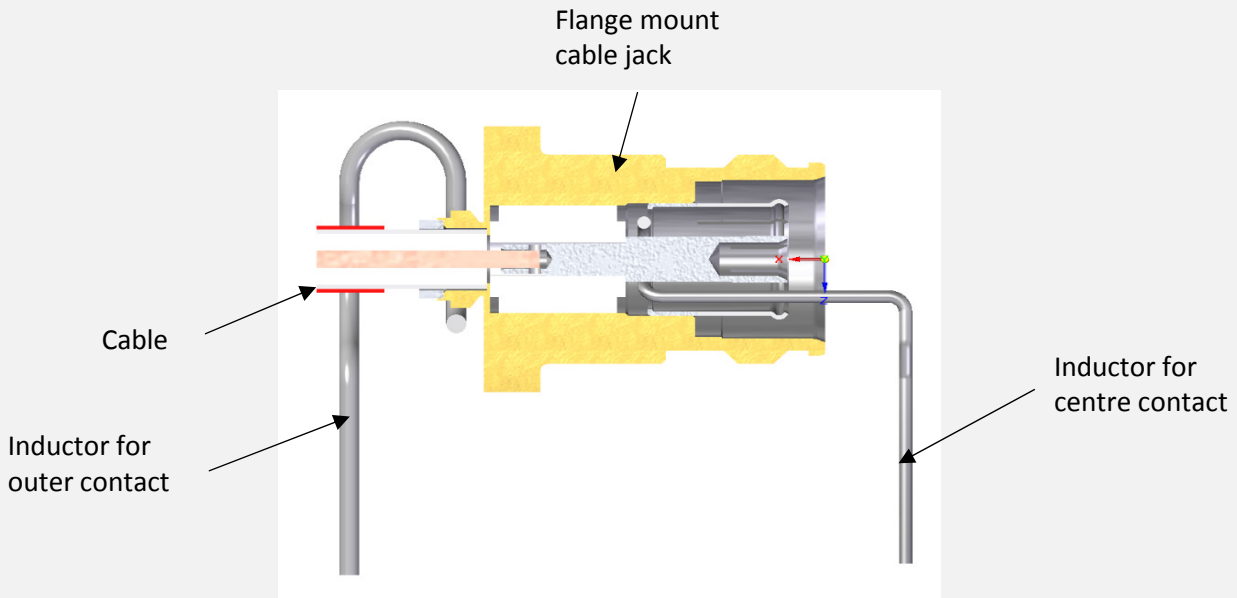

**Cable Stripping Dimension**

Cable: UT-216  
 Flexiform 401SL HFJ

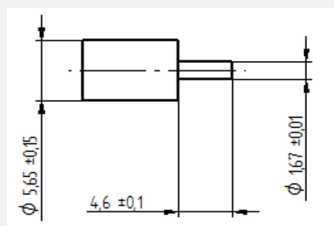

Rev.: 1	Date: 03.11.2014	Signature: R.Schwär	Alteration: Modification	Approved:
------------	---------------------	------------------------	-----------------------------	-----------

**Customer Assembly Instruction**

**Number:**

**M-260**

**Nummer:**

**Description:**

**4.3-10-Flange mount cable jack**

**Beschreibung:**

**Soldering Set-up**

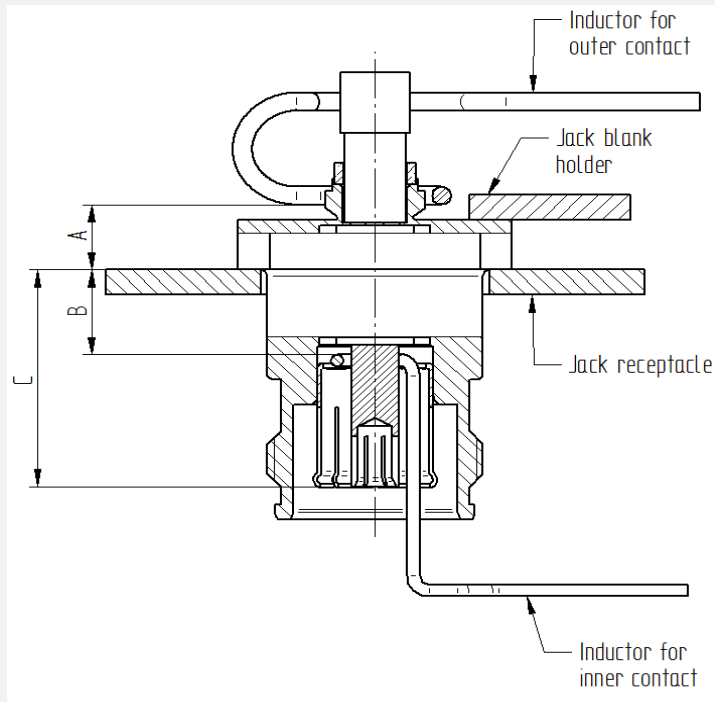

Inductor position:

- Dimension A: 5,5mm
- Dimension B: 11,95mm
- Dimension C: 23,15mm

**Soldering Parameter**

TBD

**Notes**

**Aufzeichnungen**

While the information has been carefully compiled to the best of our knowledge, nothing is intended as representation or warranty on our part and no statement herein shall be construed as recommendation to infringe existing patents. In the effort to improve our products, we reserve the right to make changes judged to be necessary.

Rev.: 1	Date: 03.11.2014	Signature: R.Schwär	Alteration: Modification	Approved:
------------	---------------------	------------------------	-----------------------------	-----------