

Assembly Instruction

Number: M-255
 Description: Cable jack

Date: 25.04.13
 Signature: Á. Varga
 Page: 1 of 1

Using parts:

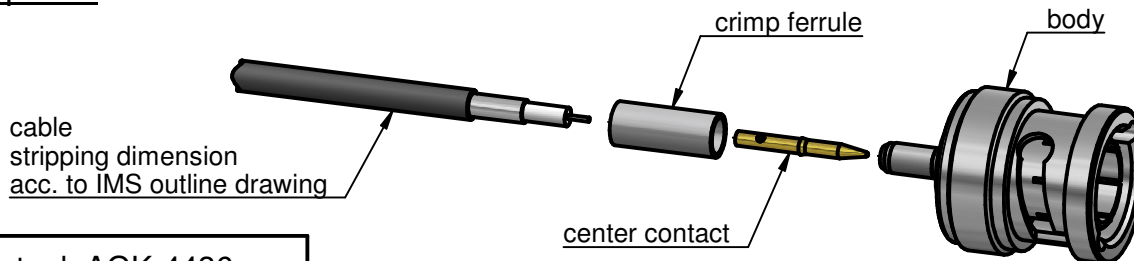

Crimp tool: AGK-4436
 Assembly aid: AGK-4443

1.) Slide the crimp ferrule and the heatsink tube (opt.) onto the cable.

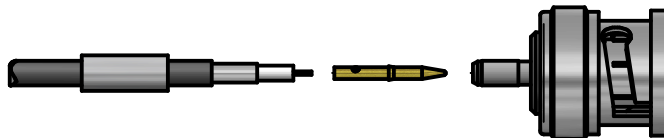

2.) Crimp or solder the center contact.

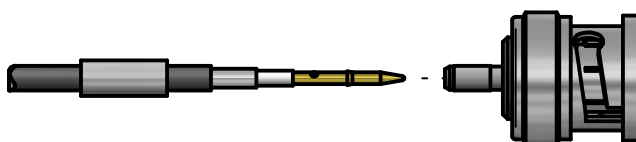

3.) Fan the braid and slide the cable into cable plug until stop in the assembly aid.

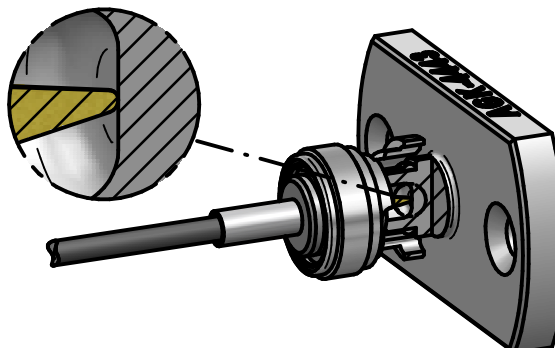

4.) Slide the ferrule over the braid, and crimp the ferrule.

